



Standard-Duty Low-Profile Conveyors - SLPC

Requiring only $1\frac{1}{8}$ inch in clearance to the top of the belt, these rugged low-profile conveyors are built to withstand the punishment of even punch presses or automated operations.



Conveyor Part Number / Standard Size Chart*

Frame Width (W)	Overall Length (L)								
	2'	3'	4'	5'	6'	7'	8'	9'	10'
2"	SLPC 020-2	SLPC 020-3	SLPC 020-4	SLPC 020-5	SLPC 020-6	SLPC 020-7	**	**	**
3"	SLPC 030-2	SLPC 030-3	SLPC 030-4	SLPC 030-5	SLPC 030-6	SLPC 030-7	**	**	**
3.5"	SLPC 035-2	SLPC 035-3	SLPC 035-4	SLPC 035-5	SLPC 035-6	SLPC 035-7	**	**	**
4"	SLPC 040-2	SLPC 040-3	SLPC 040-4	SLPC 040-5	SLPC 040-6	SLPC 040-7	SLPC 040-8	SLPC 040-9	SLPC 040-10
6"	SLPC 060-2	SLPC 060-3	SLPC 060-4	SLPC 060-5	SLPC 060-6	SLPC 060-7	SLPC 060-8	SLPC 060-9	SLPC 060-10
8"	SLPC 080-2	SLPC 080-3	SLPC 080-4	SLPC 080-5	SLPC 080-6	SLPC 080-7	SLPC 080-8	SLPC 080-9	SLPC 080-10
10"	SLPC 100-2	SLPC 100-3	SLPC 100-4	SLPC 100-5	SLPC 100-6	SLPC 100-7	SLPC 100-8	SLPC 100-9	SLPC 100-10
12"	SLPC 120-2	SLPC 120-3	SLPC 120-4	SLPC 120-5	SLPC 120-6	SLPC 120-7	SLPC 120-8	SLPC 120-9	SLPC 120-10

* Consult factory for non-standard sizes.

**Consult factory for information on these sizes.

SPECIFICATIONS FOR MAGNETIC AND NONMAGNETIC MODELS

DIMENSIONS: Standard sizes are listed in the table. (Min. width-2", max. width-12"; min. length-1', max. length-10'.) Special sizes are available on request - up to 20' in length with Integrated Center Drive option.

MAGNETIC ELEMENT: Optional permanent magnetic element with decreasing magnetic force at each end of the conveyor for smooth product release when running in either direction. Other elements are available, including one with decreasing magnetic force at one end only.

FRAME CONSTRUCTION (MAGNETIC): Formed channel body made from 11-gauge stainless steel.

FRAME CONSTRUCTION (NONMAGNETIC): Formed channel body of 11-gauge CRS.

BELT: Model E8/2 U0/U4 GS TR is standard. It is an oil-, puncture-, and abrasion-resistant endless urethane belt designed for general-purpose conveying, punch press, and oily applications. Antistatic aqua-colored urethane fabric can operate to 40 lb. per inch tensile force and 212°F. See page 20 for other belt style options, including cleated belts. (Conveyor design allows exceptionally quick belt replacement.)

BELT SPEED: Constant or variable speeds up to 120 fpm.

DRIVE PULLEY: 1 $\frac{9}{16}$ " diameter all-steel, crowned face with knurled surface for traction and $\frac{7}{16}$ " hex hollow bore drive.

DRIVE BEARING: Sealed precision self-aligning ball bearings.

TAKE-UP PULLEY: 1 $\frac{5}{16}$ " diameter crowned face with sealed precision self-aligning ball bearings.

TAKE-UP: Totally adjustable from take-up end while conveyor is running. Take-up travel allows $\frac{7}{8}$ " of belt adjustment.

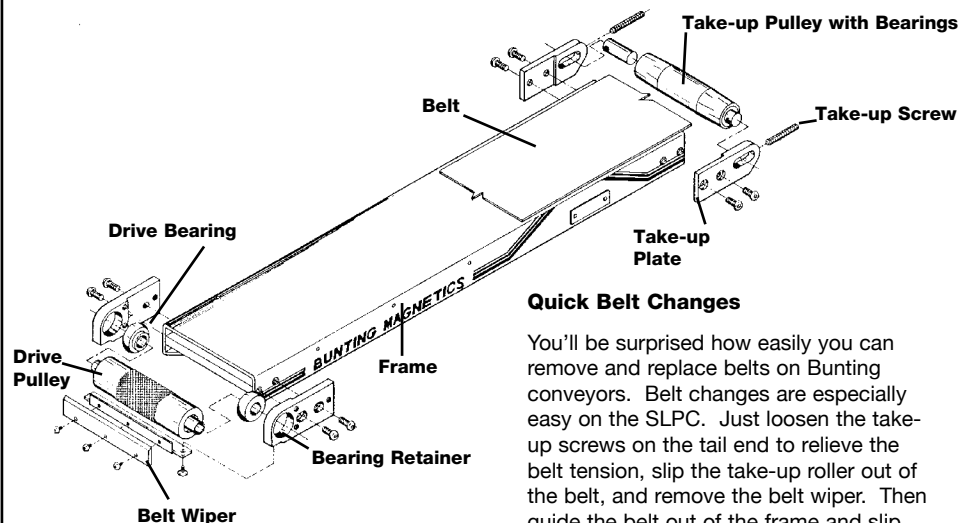
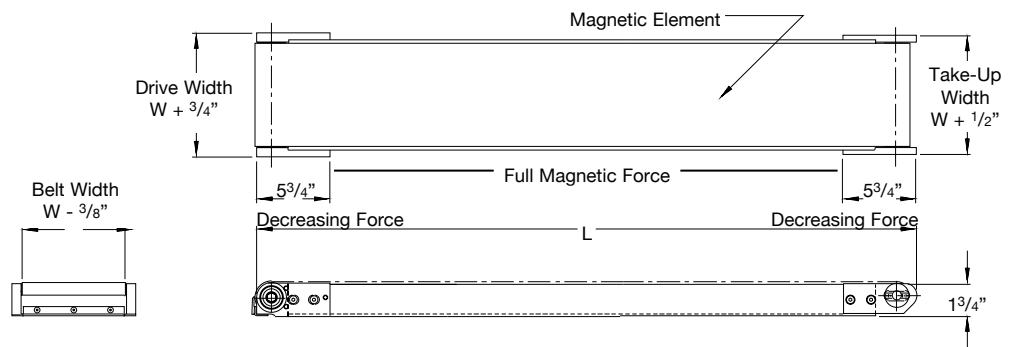

Quick Belt Changes

You'll be surprised how easily you can remove and replace belts on Bunting conveyors. Belt changes are especially easy on the SLPC. Just loosen the take-up screws on the tail end to relieve the belt tension, slip the take-up roller out of the belt, and remove the belt wiper. Then guide the belt out of the frame and slip the new belt into place.



Standard-Duty Low-Profile Conveyors - SLPC

When ordering, please specify ITD for top-mounted drive option or IBD for bottom-mounted drive option along with the frame width of the LPC intended for conversion. Also specify right- or left-hand mount. (See drawing at right.)

Rugged Center Drives are also available for use where space at conveyor ends is limited or for use on conveyors longer than 10 feet. When ordering the center drive option please specify ICD.

Gearmotor Options Include:

Fixed speed, single-phase $\frac{1}{6}$ hp, 115V, 60 Hz at 85 fpm motor – totally enclosed, equipped with switch, overload protection, and fan cooled.

Fixed speed, 3-phase, $\frac{1}{6}$ hp, 230/460V, 60 Hz at 85 fpm motor – totally enclosed, equipped with switch, overload protection, and fan cooled.

Variable speed, single-phase, $\frac{1}{8}$ hp, 90VDC, 2-120 or 1-30 fpm motor – totally enclosed, non-ventilated, equipped with switch, and speed control.

Air motor, 20-120 fpm; filters, regulator, gauge, and lubricator are available options.

Special drives are available on request. Fifteen-foot cord with switch is optional.

End Views

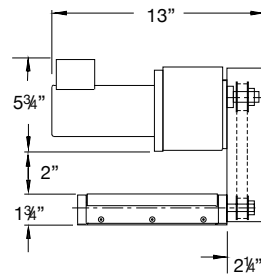
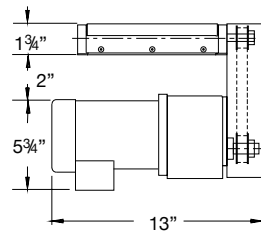

Side Views

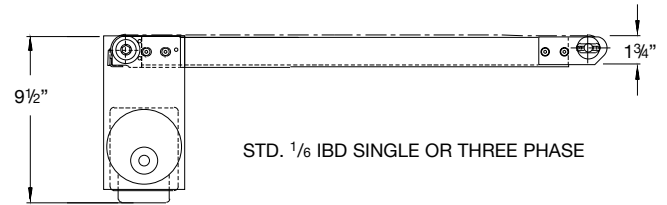

STD. $\frac{1}{6}$ IBD SINGLE OR THREE PHASE

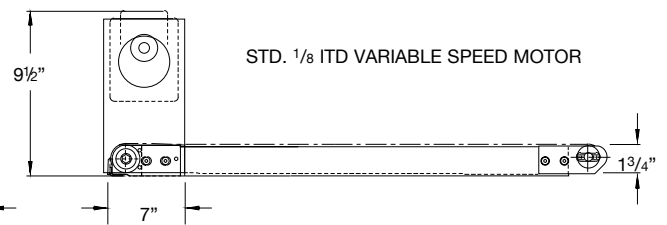

STD. $\frac{1}{8}$ ITD VARIABLE SPEED MOTOR

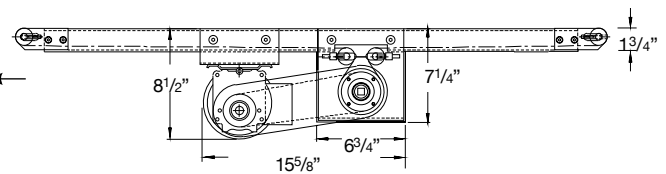
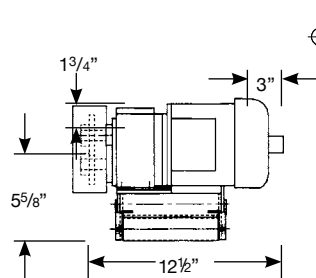

CENTER DRIVE WITH EXTENDED ENDS AND CENTER TAKE-UP SHOWING $\frac{1}{6}$ BOTTOM DRIVE

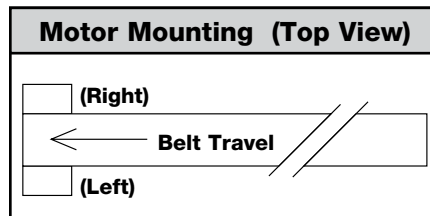

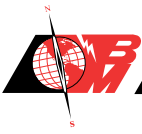

Heavy-Duty Low-Profile Conveyors - HLPC

Able to handle part and scrap removal in high-speed, heavy-load, and other demanding applications. The HLPC was designed to handle the toughest under-press jobs day after day with minimum maintenance.



Conveyor Part Number / Standard Size Chart*

Frame Width (W)	Overall Length (L)									
	2'	3'	4'	5'	6'	7'	8'	9'	10'	
2"	HLPC 020-2	HLPC 020-3	HLPC 020-4	HLPC 020-5	HLPC 020-6	HLPC 020-7	HLPC 020-8	HLPC 020-9	HLPC 020-10	
3"	HLPC 030-2	HLPC 030-3	HLPC 030-4	HLPC 030-5	HLPC 030-6	HLPC 030-7	HLPC 030-8	HLPC 030-9	HLPC 030-10	
4"	HLPC 040-2	HLPC 040-3	HLPC 040-4	HLPC 040-5	HLPC 040-6	HLPC 040-7	HLPC 040-8	HLPC 040-9	HLPC 040-10	
6"	HLPC 060-2	HLPC 060-3	HLPC 060-4	HLPC 060-5	HLPC 060-6	HLPC 060-7	HLPC 060-8	HLPC 060-9	HLPC 060-10	
8"	HLPC 080-2	HLPC 080-3	HLPC 080-4	HLPC 080-5	HLPC 080-6	HLPC 080-7	HLPC 080-8	HLPC 080-9	HLPC 080-10	
10"	HLPC 100-2	HLPC 100-3	HLPC 100-4	HLPC 100-5	HLPC 100-6	HLPC 100-7	HLPC 100-8	HLPC 100-9	HLPC 100-10	
12"	HLPC 120-2	HLPC 120-3	HLPC 120-4	HLPC 120-5	HLPC 120-6	HLPC 120-7	HLPC 120-8	HLPC 120-9	HLPC 120-10	

* Consult factory for non-standard sizes.

STANDARD SPECIFICATIONS FOR MAGNETIC AND NONMAGNETIC MODELS

DIMENSIONS: Standard sizes are listed in the table. (Min. width-2", max. width-12"; min. length-18", max. length-10'.) Special sizes are available on request.

MAGNETIC ELEMENT: Optional permanent magnetic element provides decreasing magnetic force at each end of the conveyor for smooth product release when running in either direction. Other elements are available — including one with decreasing magnetic force at one end only.

FRAME CONSTRUCTION: Formed channel outer body of 11-gauge CRS with 16-gauge stainless steel formed channel slider bed, bolted to form an integral box construction. Drive panel is $\frac{3}{16}$ " CRS material for rigidity.

BELT: Model E8/2 U0/U4 GS TR is standard. It is an oil-, puncture-, and abrasion-resistant endless urethane belt designed for general-purpose conveying, punch press, and oily applications. Antistatic aqua-colored urethane fabric can operate to 40 lb. per inch tensile force and 212°F. See page 20 for other belt style options, including cleated belts.

BELT SPEED: Constant or variable speeds up to 250 fpm.

DRIVE PULLEY: 3 $\frac{1}{2}$ " diameter all-steel crowned face with heavy knurled surface for traction and $\frac{1}{2}$ " square hollow bore drive.

TAKE-UP PULLEY: 1 $\frac{5}{16}$ " diameter crowned face with sealed precision self-aligning ball bearings.

TAKE-UP: Adjustable from take-up end while conveyor is running. Take-up allows $\frac{7}{8}$ " of belt adjustment.

DRIVE BEARING: Heavy-duty 2" diameter sealed precision self-aligning ball bearings.

SNUB ROLLER: 1 $\frac{5}{16}$ " diameter flat face with sealed precision bearings.

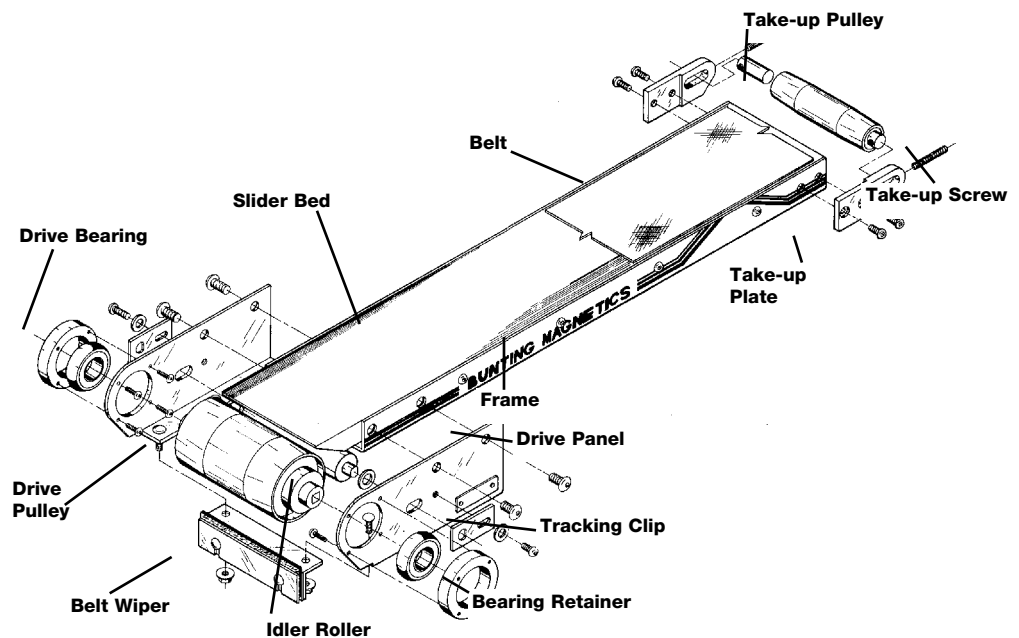
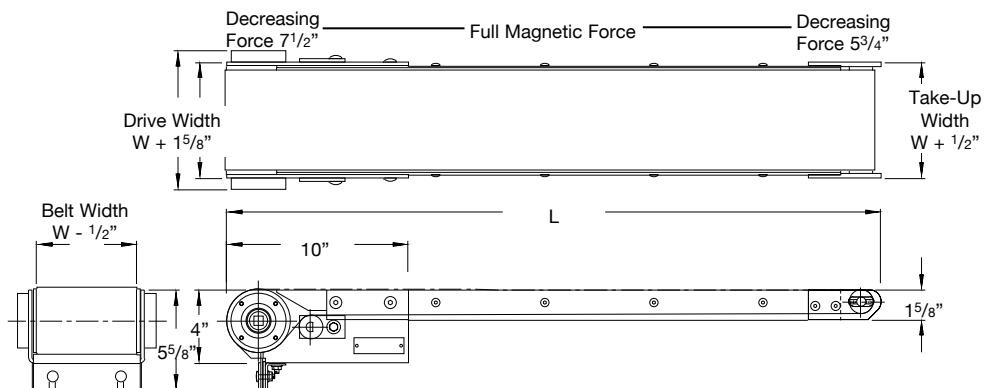



Heavy-Duty Low-Profile Conveyors - HLPC

Individual Conveyor Drive Options

All Bunting HLPCs can be driven individually for use in areas requiring single conveyors. Individual conveyor drive options offer you the choice of a top- or bottom-mounted motor which can be mounted on the left or right side of the conveyor. The standard drive package contains all necessary parts and hardware to make the conversion between left and right side locations.

Choose between top- or bottom-mount and right- or left-handed drive components for the HLPC.

When ordering, please specify ITD for top-mounted drive option or IBD for bottom-mounted drive option along with the frame width of the conveyor. Also specify right- or left-hand mount.

Our standard inline gearmotors provide power through a chain and sprocket drive housed in a rugged chain guard. The drive mechanism uses a strong, durable #40 roller chain. To accommodate parts that are wider than the conveyor, the chain guard is located below the belt surface on the bottom-mounted drive option.

Gearmotor options include:

Fixed speed, single-phase, $\frac{1}{6}$ hp, 115V, 60 Hz, 70 fpm motor — totally enclosed and fan cooled.

Fixed speed, single-phase, $\frac{1}{3}$ hp, 115V, 60 Hz, 70 fpm motor — totally enclosed and fan cooled.

Fixed speed, 3-phase, $\frac{1}{3}$ hp, 230/460V, 70 fpm — totally enclosed and fan cooled.

End Views

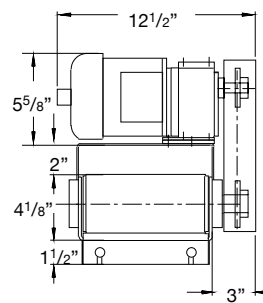

Side Views

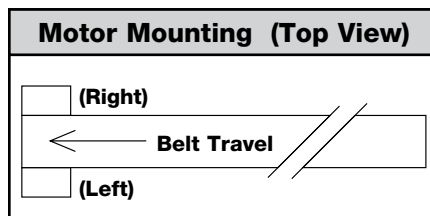
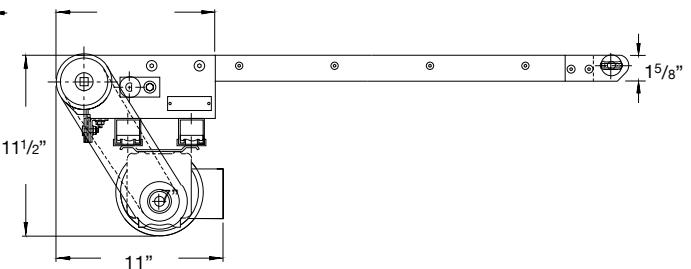
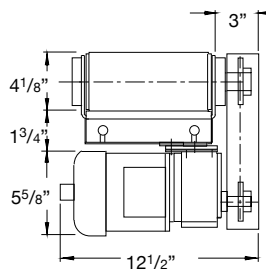
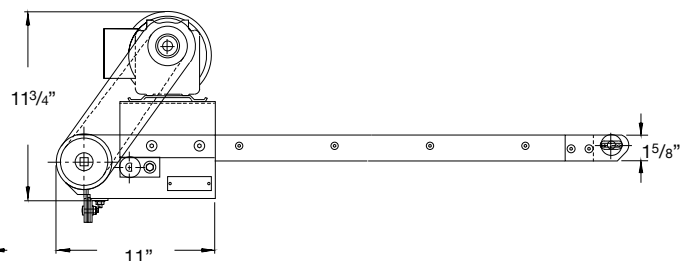



Low-Profile Conveyors

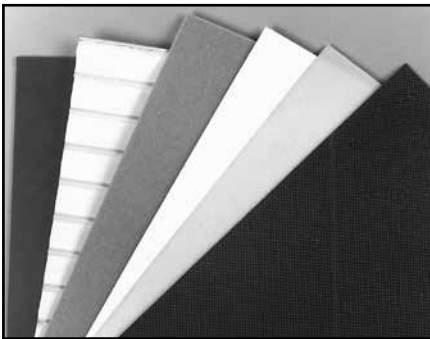

Standard SLPC / HLPC Belt

MODEL E 8/2 U0/U4 GS TR

Standard on SLPC and HLPC

- Designed for general-purpose conveying, punch press, and oily applications
- 2-ply aqua-colored urethane
- Polyester fabric, antistatic
- Surface has an inverted diamond pattern
- Admissible tensile force is 40 lb. per inch
- Total belt thickness is .08 inch
- Maximum operating temperature is 212°F

Select the belt designed for your SLPC/HLPC application

The following belt descriptions will help you select the proper belt for your application. All standard supplied belts are endless. This alleviates many of the belt problems caused by splice failures on laced belts that run on small diameter pulleys. Belts on the SLPC can be replaced so quickly that all recommended replacement belts are endless. It does take somewhat longer to change the belt on the HLPC. Consult us for assistance in selecting belts for special applications. Only factory-approved belts should be used.

Optional Belts

MODEL E 3/2 U0/U0

- Designed for accumulating or diverting parts
- 2-ply tan urethane belt
- Polyester fabric, antistatic
- Surface is slightly textured and very slick
- Admissible tensile force is 40 lb. per inch
- Total belt thickness is .05 inch
- Maximum operating temperature is 212°F

MODEL E 8/2 U0/U8

- Designed for use under punch press conveying sharp parts or scrap
- 2-ply clear-top urethane belt
- Polyester fabric, antistatic
- Surface is smooth .030" thick urethane
- Admissible tensile force is 40 lb. per inch
- Total belt thickness is .08 inch
- Maximum operating temperature is 212°F

MODEL E 4/2 U0/U2

- Designed for general-purpose conveying and diverting small dry parts; FDA approved
- 2-ply white urethane belt
- Polyester fabric, antistatic
- Surface is smooth, slick, and hard
- Admissible tensile force is 22 lbs. per inch
- Total belt thickness is .05 inch
- Maximum operating temperature is 212°F

RIB CLEAT

- Used for conveying on incline conveyors and with round parts where roll-back is a concern
- 3-ply white Buna-N belt
- Polyester fabric, antistatic
- Surface has 1/8" high cleats on 1" centers
- Admissible tensile force is 135 lbs. per inch
- Maximum operating temperature is 250°F

CLEATED BELT

- Used primarily on nonmagnetic conveyors for conveying round parts on inclines
- 2-ply white PVC or urethane
- Polyester fabric
- 1/8" to 1 1/2" high cleats on 1" centers
- Admissible tensile force is 40 lbs. per inch
- Maximum operating temperature is 212°F



Low-Profile Conveyors

Easy Belt Tension Adjustment

To adjust belt tension, loosen the take-up set screws. Then tighten the adjustment screws an equal number of turns until the belt is taut enough to prevent slipping on the drive pulley under maximum expected load. SLPCs and HLPCs that are run in reverse require slightly tighter belt tensions.

Easy Tracking Adjustment

Bunting SLPCs and HLPCs are trackable conveyors. Their pulleys can be adjusted to center the belt in the frame. In addition to the adjustable tail pulley, the self-aligning drive bearings allow the drive pulley to be angled slightly. Under most conditions, the belt will track to the center with the pulleys square to the frame. But occasionally the pulleys need to be angled to compensate for a belt that is not perfectly straight.

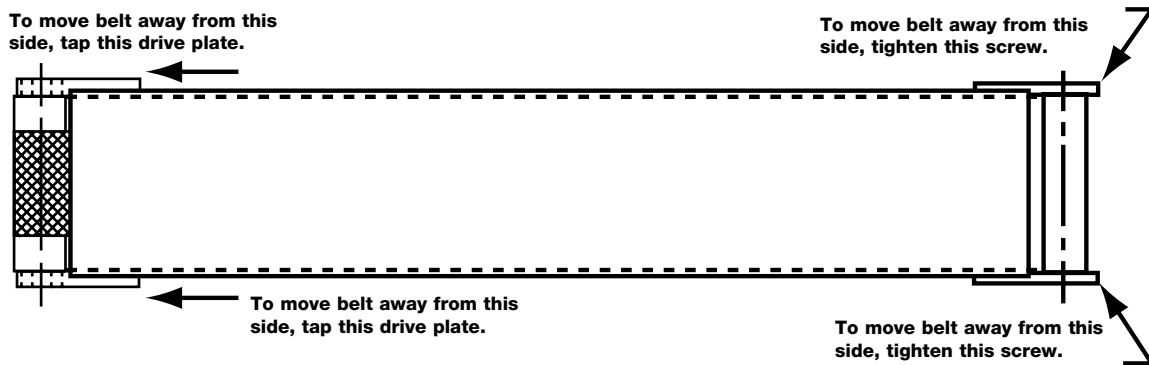

Floor Supports

Double supports allow free-standing installation. When one end of the conveyor rests on a press or other plant equipment, a single floor support can be used. Height adjusts ± 3 ". When ordering, specify overall height desired from floor to top of belt and model number of conveyor.

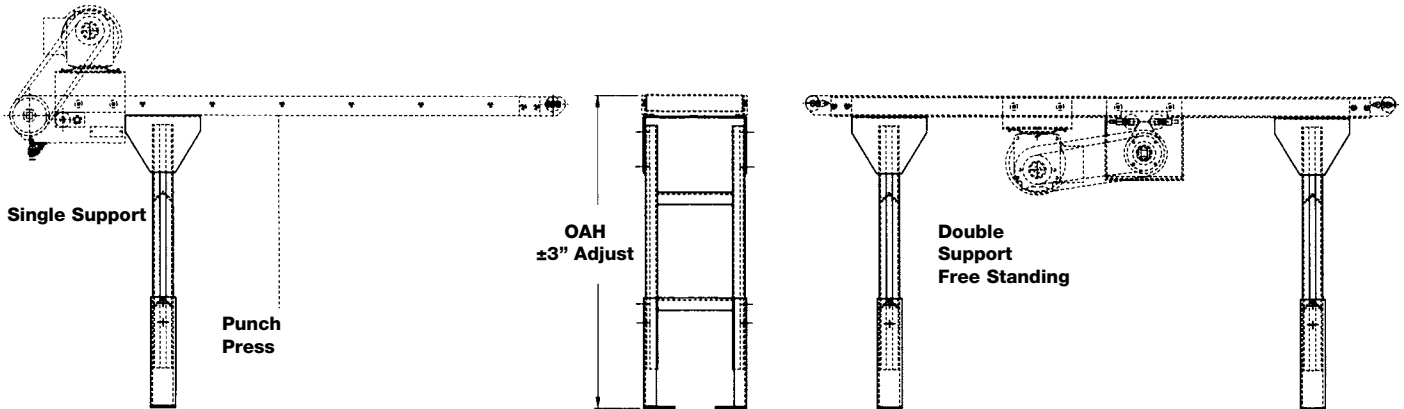

Side Guards

These basic fixed-height guards (and other adjustable guards not shown) bolt to the conveyor frame with supplied #10-32 screws. Guards help keep parts and scrap on the belt, away from frame and belt edges.

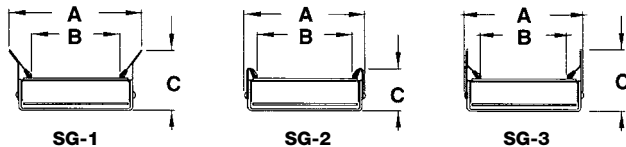

	Frame Width A	Frame Width B	Overall Height C
HLPC SG-1	+1"	-7/8"	3 1/8"
SG-2	+3/8"	-1"	2 1/4"
SG-3	+3/8"	-7/8"	3 1/8"
SLPC SG-1	+1"	-3/4"	3 1/4"
SG-2	+3/8"	-7/8"	2 3/8"
SG-3	+3/8"	-7/8"	3 1/4"

Specifications subject to change without notice.