

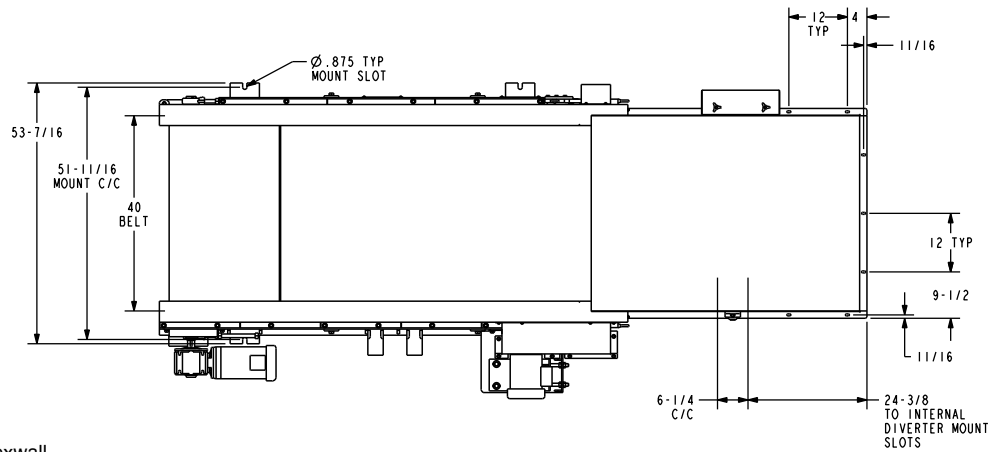

# Eddy Current Separator

Bunting Eddy Current Separators are available in 24", 36", 48" and 60" widths to provide non-ferrous conductive metal separation from non-conductive recycled materials. These are used extensively in the Plastics, Municipal, Electronics, Glass and Metal Recycling Industries to separate shredded aluminum, aluminum cans, bottle caps, hard drive housings and circuit board components into purer higher value product and metal streams.

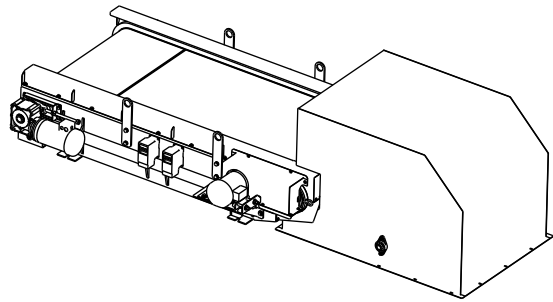
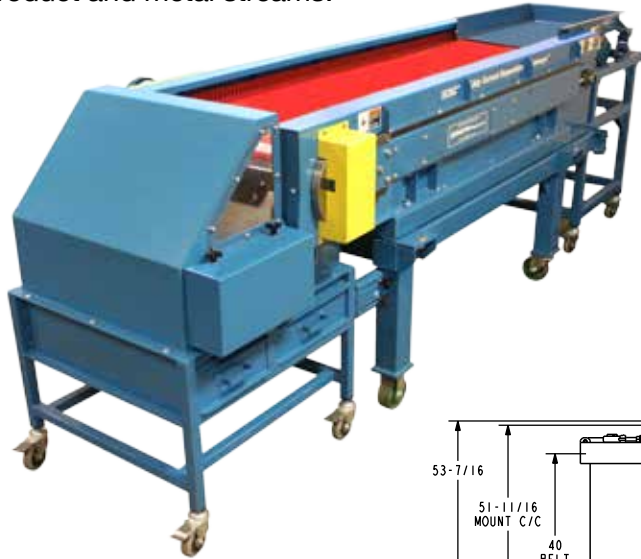

**SPECIFICATIONS:** Available in widths of 24", 36"; 48" and 60"

**CONVEYOR LENGTH:** All conveyors are 8' long

**BELTS:** 2-ply monofilament urethane belts with flexwall edges and sweeper cleats

**SIDE GUARDS:** Formed metal sideguards that are formed up and over the flexible wall edge

**MOTORS:** Dual motors for both the eddy rotor and the conveyor belt. Motors are sized based on the conveyor size.

**SUPPORTS:** Machine bases available on request

**SPLITTER HOOD:** Smaller Flake Eddy hood shown above. Larger hoods for MRF are available.

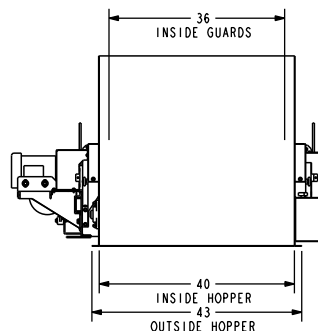
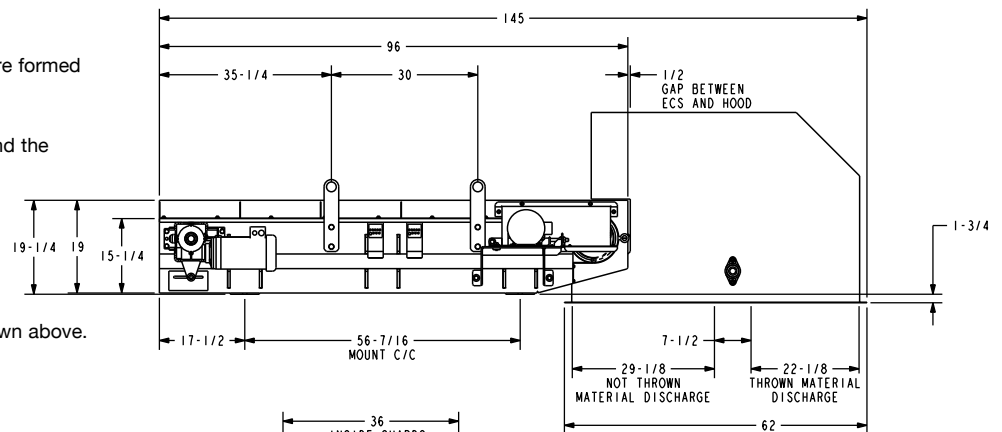

Effective Belt Width	OAW
24	62
36	74
48	87
60	99